

OVEN TYPE	A
1 CHAMBER	190
2 CHAMBERS	190
3 CHAMBERS	80

PANS 46X66				
C	D	E	F	
1350	1570	1680	1855	

PANS 46X76				
C	D	E	F	
1550	1770	1880	2055	

USEFUL H.	180	230	280
B	310	360	410

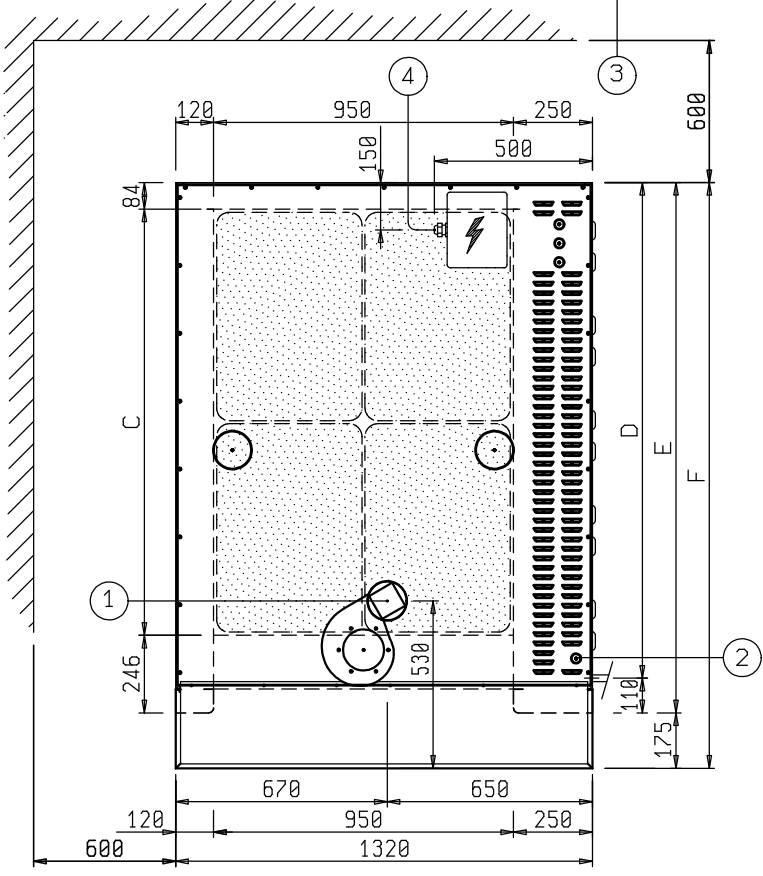

TECHNICAL FEATURES	WITH ECONOMIZER	/
INSTALLED POWER FOR SINGLE CHAMBER (KW)	4,3 KW	8,5 KW
AVERAGE CONSUMPTION FOR SINGLE CHAMBER	5 KW/H	
INSTALLED POWER PROOFER	0,5 KW	
AVERAGE CONSUMPTION PROOFER	0,5 KW	
ELECTRIC POWER FOR STEAM GENERATOR FOR SINGLE CHAMBER	1 KW	
USEFUL DIMENSIONS BAKING CHAMBER	950 X C	
MINIMUM PASSAGE FOR DISSEMBLED OVEN	800 X 1350	

1 STEAM EXHAUST PIPE	∅120
2 WATER ARRIVAL	∅1/2"
3 WATER DISCHARGE	∅1/2"
4 ELECTRIC ENERGY ARRIVAL	

MODULAR OVEN
4 PANS 46X66 - 46X76
WITH PROOFER



DATA .
 BOLL. .

UISTO .
 DIS. SA.

DATA 06.03.07
 DIS.N° POS/573

Sistema Qualita'

DISEGNO DI PROPRIETA' RISERVATA E NON PUO' ESSERE RIPRODOTTO O MOSTRATO A TERZI AI SENSI DI LEGGE